

Parts list

Item	Description
1	Stud
2	Washer
3	Under valve cover
4	O Ring
5	Lower Stem
6	Bearing
7	Drain Valve
8	Stud
9	Nut
10	Right Body
11	Bonnet
12	Washer
13	Stud
14	Nut
15	Stud
16	Washer
17	Stem
18	Worm
19	Key
20	Bearing
21	Body
22	Ball
23	Ring
24	Seat
25	Stud
26	Spring
27	O Ring
28	Left Body
29	Nut

Standard Valve Trim Materials

API6A Materials Classification	Body&Bonnet Material	Stem Material/Coating	Gate Material/Coating	Seat Material/Coating
AA-General Service	Low Alloy Steel	AISI 41XX Nitrided	AISI 41XX Nitrided	AISI 41XX Nitrided
BB-General Service	Low Alloy Steel	AISI 41XX Nitrided	AISI 41XX Nitrided	Stellite™3
CC-General Service	AISI 410 SS	AISI 410SS	AISI 410 Nitrided	Stellite™3
DD-Sour Service	Low Alloy Steel	AISI 41XX Nickel-plated	AISI 41XX Hard-faced	Stellite™3
EE-Sour Service	Low Alloy Steel	AISI 410 Nitrided	AISI 41XX Hard-faced	Stellite™3
FF-Sour Service	AISI 410 SS	AISI 410 Nitrided	AISI 41XX Hard-faced	Stellite™3
HH-Sour Service	Low Alloy Steel Clad with Alloy 625 or Solid Alloy 718	Alloy 718	Alloy 718 Hard-faced	Stellite™3

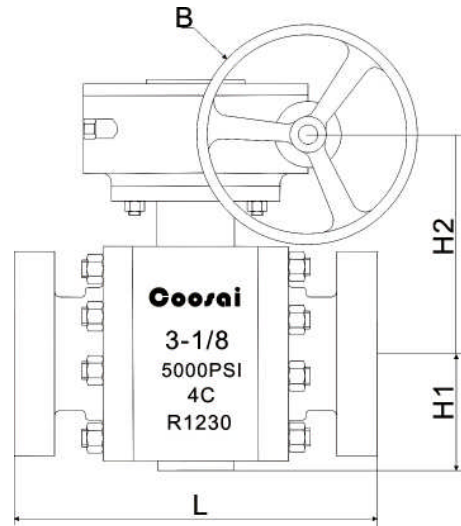

外形尺寸(mm)

Pressure	NPS	L			B	H1	H2	Weight (Kg)
		Flanged	Threaded	Butt weld				
2000 PSI	2-1/16 "	295	-	-	356	133	391	75.5
	2-9/16 "	333	-	-	356	152	410	96
	3-1/8 "	359	-	-	356	181	484	115
	4-1/8 "	435	-	-	356	232	525	168
	6-1/8 "	562	-	-	467	327	635	384
3000PSI	2-1/16 "	371	-	-	356	137	391	81.6
	2-9/16 "	422	-	-	356	165	410	106
	3-1/8 "	435	-	-	356	187	484	125
	4-1/8 "	511	-	-	467	232	525	216
	5-1/8 "	613	-	-	610	289	573	360
	6-1/8 "	613	-	-	610	327	610	480
5000PSI	2-1/16 "	371	-	-	356	143	441	84
	2-9/16 "	422	-	-	356	165	460	110.5
	3-1/8 "	473	-	-	467	187	484	173
	4-1/8 "	549	-	-	467	232	525	250
	5-1/8 "	727	-	-	610	289	598	384
	6-1/8 "	737	-	-	610	327	610	557
10000PSI	1-13/16 "	464	-	-	356	146	441	120
	2-1/16 "	521	-	-	467	149	441	132
	2-9/16 "	565	-	-	467	173	460	178
	3-1/16 "	619	-	-	610	207	478	231
	4-1/16 "	670	-	-	610	256	532	423
	5-1/8 "	737	-	-	610	333	641	840

Note: Flange end API 6B